

Für Holzzargen

Tragkraft pro Band 20 kg

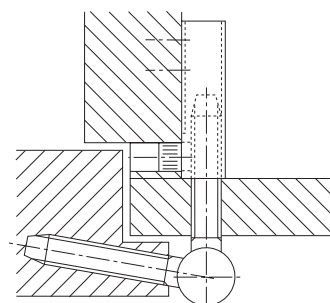

Artikel	Material	Oberfläche	Salznebel-sprühtest (Std.)	Verpackung
489772	Stahl	brüniert	2	200
836095	Edelstahl	Edelstahl satiniert		20
843408	Stahl	verchromt	20	20
494247	Stahl	vergoldet	3	20
489771	Stahl	vermessingt	4	200
482628	Stahl	vernickelt	20	200
843409	Stahl	weiss RAL 9010	1000	50
678588	Stahl	weiss verzinkt	120	200



a	c	d	e	f	g	h
mm	mm	mm	mm	mm	mm	mm
15,0	40,0	50,0	7,0	22,0	10,0	24,0

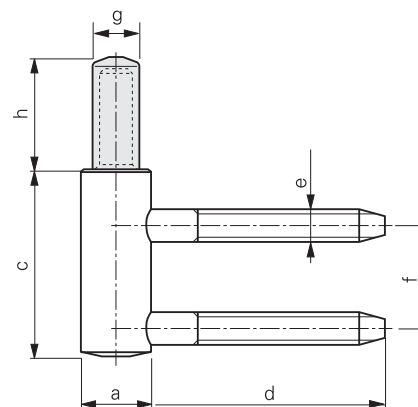

Kombinierbar mit

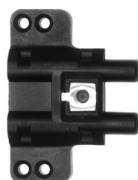

10L-15-F21	012-RM-017
p. 6.1 2	p. 8.2 6